

E/EL Pulverizer Bottom Ring Lifting Clamp

Purpose

Alert customers on safety procedures when using the Babcock & Wilcox bottom grinding ring lifting clamp.

Problem

The Babcock & Wilcox lifting clamp is designed only to lift the bottom ring off the ring seating surface of the yoke and to position the ring back on top of the ring seating surface of the yoke, when the bottom ring is completely inside the pulverizer housing (see Figure 1).

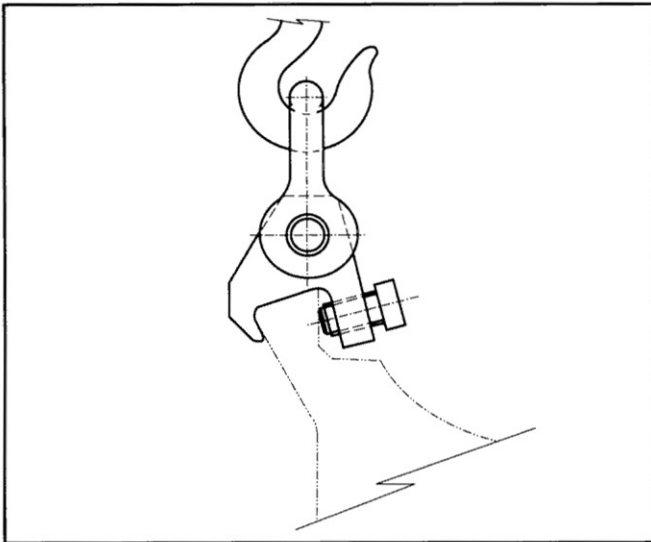

Figure 1 Typical clamp for lifting a ring on the outside diameter.

We have found that many customers use the lifting clamp to transport the used bottom grinding rings out of the pulverizer and transport new bottom grinding rings into the pulverizer. The possibility exists for the lifting clamp to slip, especially when transporting.

Recommendations:

The lifting clamp should be used in the following manner:

Ring Removal

1. Grasp the ring with the lifting clamps and lift it just high enough to install wooden blocks between the ring and the ring seating surface of the yoke (see Figure 2).
2. Lower the ring on to the blocks. (Attach rope to each block for easy removal.)
3. Remove the lifting clamps.
4. Wrap chokers around the ring for safe transporting out of the pulverizer.

Ring Installation

1. Wrap chokers around the ring for safe transporting to and into the pulverizer.
2. Lower the ring on to the wooden blocks.
3. Remove chokers and grasp the ring using the lifting clamps.
4. Remove the wooden blocks and lower the ring into place.
5. Remove the lifting clamps.

(Continued on reverse side)

Warning

The lifting clamp **must** not be used to transport the bottom ring. Use of the lifting clamp to transport the ring can result in equipment damage and personnel injury.

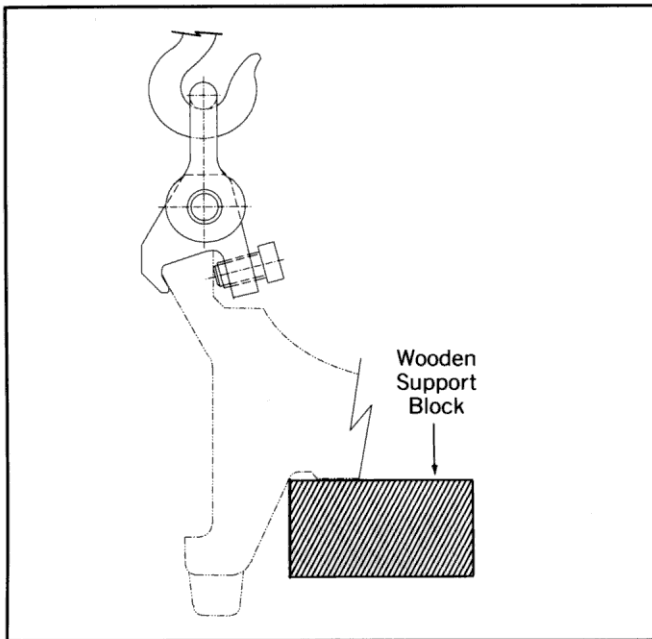

Figure 2 Clamp showing typical block location.

Personnel **must** keep their hands and feet from under the ring while it is supported by the lifting clamp because, due to the hardness of the ring material and configuration of the outer lip (especially of a worn ring), *there is always the possibility that the lifting clamp may slip.*

Figure 3 shows a typical clamp for lifting a two piece ring inside the pulverizer. The procedure above should be followed in the same manner.

Support:

Contact your local Babcock & Wilcox Field Service Engineering Office if you have any questions or require assistance on the use of the various lifting clamps.

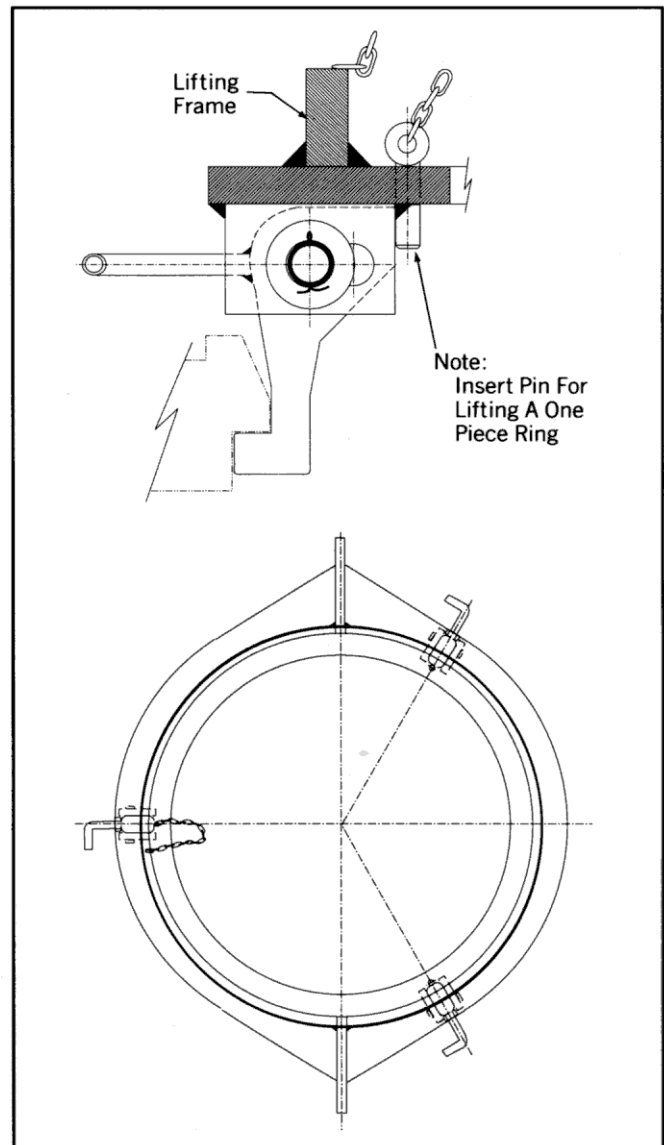

Figure 3 Typical clamp for lifting a two piece ring on the inside diameter.

For more information, contact your nearest B&W sales office or write: Dept. CIC, Power Generation Group, Babcock & Wilcox, Barberton, Ohio 44203, U.S.A.; or, in Canada, Manager, Marketing and Sales, B&W Canada, Cambridge, Ontario, N1R 5V3.

Akron (Copley), Ohio
 Atlanta, Georgia
 Boston (Dedham), Massachusetts
 Calgary, Alberta, Canada
 Cambridge, Ontario, Canada
 Charlotte, North Carolina
 Cherry Hill, New Jersey
 Chicago (Lisle), Illinois

Cincinnati, Ohio
 Dallas, Texas
 Denver (Lakewood), Colorado
 Halifax (Dartmouth), Nova Scotia, Canada
 Houston, Texas
 Kansas City, Missouri
 Los Angeles (Los Alamitos), California
 Minneapolis (St. Paul), Minnesota

Montreal, Quebec, Canada
 Portland, Oregon
 Saint Johns, New Brunswick, Canada
 St. Petersburg, Florida
 San Francisco (Walnut Creek), California
 Vancouver (Richmond), British Columbia, Canada

For international sales offices and representatives write: Manager, Marketing and Sales, Babcock & Wilcox International Division, Cambridge, Ontario, Canada N1R 5V3, or Barberton, Ohio U.S.A. 44203.

The information contained herein is provided for general information purposes only, and is not intended or to be construed as a warranty, an offer, or any representation of contractual or other legal responsibility.